

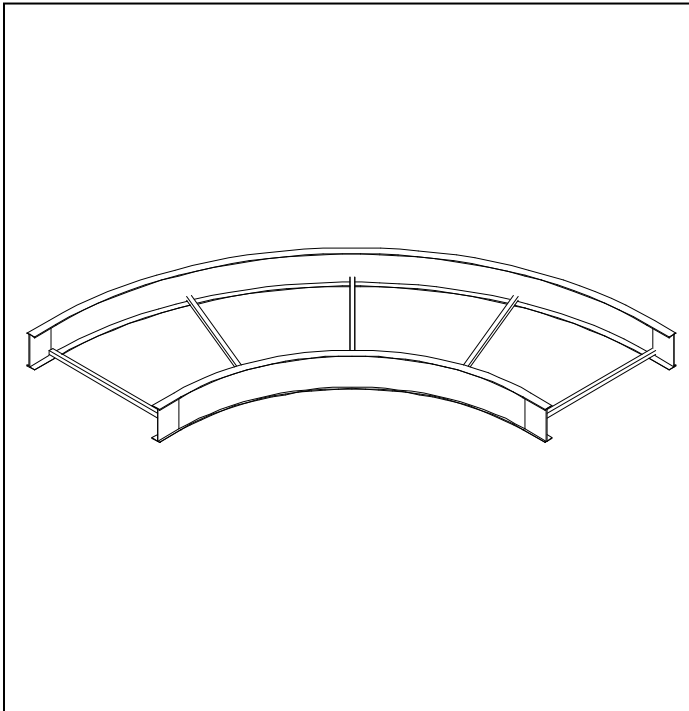

ASP 90° Turn Cable Trays

90° Turn Bend Transition Cable Trays

Specification Sheet



Materials

Cable Trays: All ASP Cable Trays and components are engineered to work together as a continuous system as well as stand-alone elements. ASP 90° Cable Trays offers a 24" bend radius for ease of coax installation and are available in standard depth of 4" with optional depth of 6". Easily connects to any ASP cable tray with splice clamps provided.

Materials: Aluminum or hot dip galvanized steel

Options: Widths of 12", 18" or 24"; Depths of 4" or 6"; Custom sizes available

Accessories: Cable Tray Supports; Covers in various finishes

Installation:

- A. Verify that roof surface is smooth and clean to extent needed to receive materials.
- B. Review approved final drawings to determine the locations of Cable Trays.
- C. Clean surfaces to receive Cable Tray Supports removing any loose gravel and any foreign matter before setting Cable Tray Supports.
- D. Accurately locate Cable Tray supports in locations specified as per approved shop drawings or as required by site conditions.
- E. Attach Cable Trays to Cable Tray Supports and connect to other Cable Trays with splice clamps to form continuous system.
- F. Adjust height of each Cable Tray Support and correct height if necessary.
- G. Repeat until all support Cable Trays supplied are installed in accordance with approved shop drawings.
- H. Remove any unused materials and packaging from job site.

This print/image and design and detail shown hereon is the property of Advanced Support Products, Inc. This print is furnished with the understanding that it is not to be reproduced without permission, and must be returned upon demand. All rights of design and invention are reserved by Advanced Support Products.

Patents #5816554 ; #6229497; #6427965; #6448497; #6578827 © 2010