

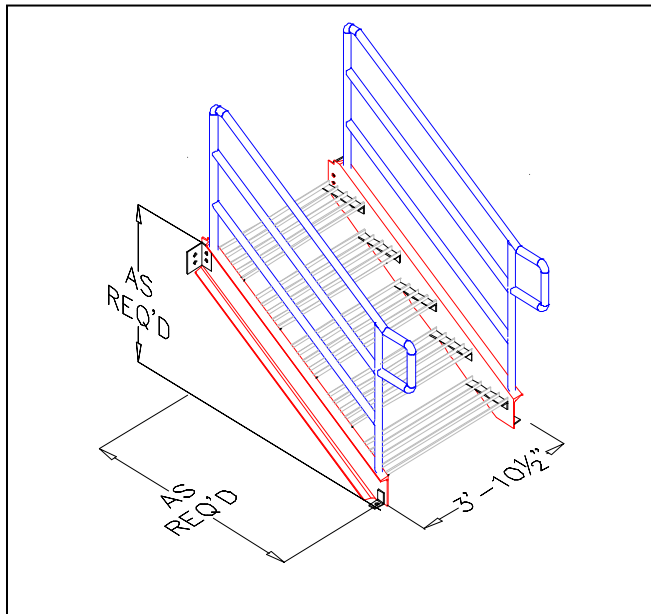

# ASP4860ST

## Stairs

## Specification Sheet



**ASP4860ST – Stairs** – Is designed to attach directly to any ASP platform or existing platform where stair access is required. Angle brackets used to attach top of stairs to platform. Width varies to fit into size of opening in either a guardrail or handrail.



### Materials

**Frame:** 10" Channel with 2" X 2" Angle Iron for risers, ASTM 572, grade 50; steps are 1" X 3/16" bar grating, 19-W-4 carbon steel, ends capped with 1" X 3/16" steel flat bar, welded, hot-dip galvanizing after fabrication.

**Handrails:** 1-1/2" schedule 40 pipe, welded to stairs; all steel ASTM 572, grade 50, hot-dip galvanizing after fabrication.

**Hardware:** Angle brackets; 3/4" X 1-1/2" Bolts and 3/4" Nuts available in Hot-Dip Galvanized finish.

**Accessories:** Protection Pads

### **Installation:**

- A. Verify that roof surface is smooth and clean to extent needed to receive materials.
- B. Review approved final drawings to determine the locations of Stairs.
- C. Clean surfaces to receive Stairs removing any loose gravel and any foreign matter before setting Stairs.
- D. Accurately locate and align pre-fabricated Stairs in locations specified as per approved shop drawings or as required herein and by site conditions.
- E. Should the roofing manufacturer require a separation sheet between the roof and the Stairs, place a separation sheet or protective pad conforming to the existing roof manufacturer's system under each Stairs. Do not adhere to the roof system or to Stairs.
- F. Repeat until Stair unit supplied is installed in accordance with approved shop drawings.
- G. Remove any unused materials and packaging from job site.

This print/image and design and detail shown hereon is the property of Advanced Support Products, Inc. This print is furnished with the understanding that it is not to be reproduced without permission, and must be returned upon demand. All rights of design and invention are reserved by Advanced Support Products.

Patents #5816554 ; #6229497; #6427965; #6448497; #6578827 © 2010