

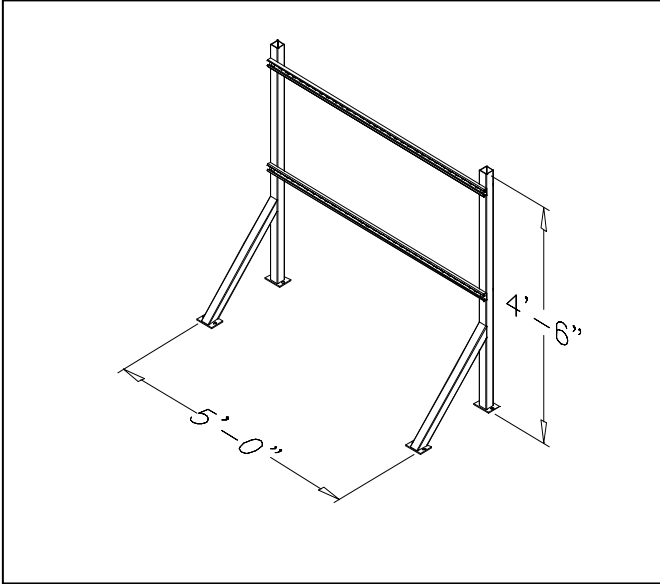

ASP5460 Power/Telco Rack

Power/Telco Rack for ASP Platforms

Specification Sheet



ASP5460L Power/Telco Rack – Is designed to be easily attached to any ASP equipment or work platform. Each Power/Telco Rack attaches directly to the platforms by bolting through the grating floor using 4 bolts 2-1/2" long with nuts provided. Each Power/Telco Rack can be manufactured in various sizes.

Materials

Power/Telco Rack: Frame made of 1" Square Tubing, welded to 2"X2"X1/4" flat plate with holes drilled for bolting directly to the grating floor of the platforms. Cross brace is 1-5/8" strut in HDG finish. All steel hot dip galvanized after fabrication.

Hardware: 2-1/2" X 1/2" bolts; 1/2" Nuts available in Hot-Dip Galvanized finish.

Accessories: Available in various sizes

Installation:

- A. Verify that roof surface is smooth and clean to extent needed to receive materials.
- B. Review approved final drawings to determine the locations of Power/Telco Rack.
- C. Clean surfaces to receive Power/Telco Rack of any foreign matter before setting Power/Telco Rack.
- D. Accurately locate and align pre-fabricated Power/Telco Rack in locations specified as per approved shop drawings.
- E. Attach Power/Telco Rack to grating floor of platform floor using bolts and nuts provided.
- F. Repeat until all Power/Telco Racks supplied are installed in accordance with approved shop drawings.
- G. Remove any unused materials and packaging from job site.

This print/image and design and detail shown hereon is the property of Advanced Support Products, Inc. This print is furnished with the understanding that it is not to be reproduced without permission, and must be returned upon demand. All rights of design and invention are reserved by Advanced Support Products.

Patents #5816554 ; #6229497; #6427965; #6448497; #6578827 © 2010