

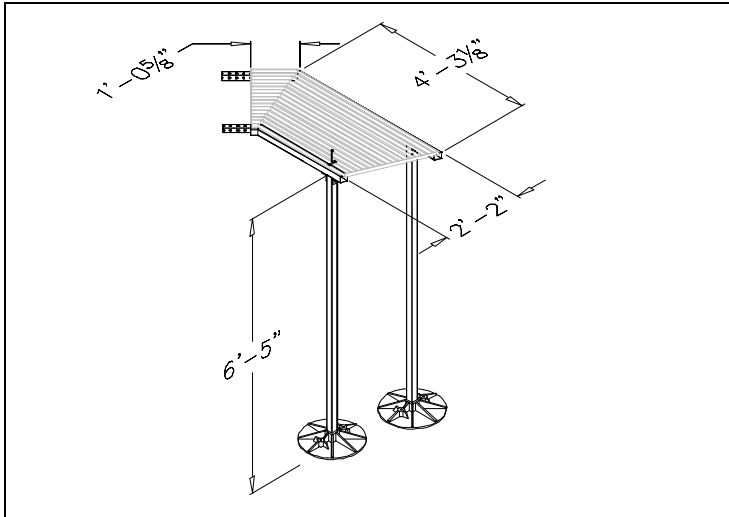

ASP902-IB45

45 ° Waveguide Support Extension

Specification Sheet



ASP202-IB45 – 45° Waveguide Support Extension – Is designed specifically for use with any ASP Waveguide Support straight section to accommodate the waveguide 45° turns. Top protection grate keep cables under cover.

Materials

Support Base: 17" circular base, injected molded polypropylene, with 227 sq. in. of surface on bottom, designed for weight displacement.

Base Dimensions: 3"H X 17" in diameter, designed for weight displacement, with molded insert for square tubing and two threaded rod couplings molded in.

LEED: Minimum 40 % post industrial recycled polypropylene with UV inhibitors.

Waveguide support: 2"X2" 11 GA square tubing; 1-5/8"X1-5/8" strut; 1" X 3/16" bar grating, 19-W-4 carbon steel, ends capped with 1" X 1/4" steel flat bar; Hot-Dip Galvanized after fabrication.

Hardware: 1/2" X 3" Bolts with 1/2" Nuts and Washers; 1/2" Spring Nuts for adjustable heights; Grating Clips with 1-1/2 " Self Tapping Screws; available in Pre-Galvanized Zinc coated or Hot-Dip Galvanized.

Accessories: Protection Pads; Trapeze Hangers

Model	Dimensions			Weight
	Length	Width	Height	
ASP902-45	4'3"/1.25m	2'2"/.660m	6'5"/1.956m	160 lb/72.574kg

Custom sizes and heights are available.

Installation:

- Verify that roof surface is smooth and clean to extent needed to receive materials.
- Review approved final drawings to determine the locations of Waveguide Support.
- Clean surfaces to receive 17" circular bases removing any loose gravel and any foreign matter before setting 17" circular support bases.
- Accurately locate Waveguide Support in location specified as per approved shop drawings or as required herein and by site conditions. No Isolation pads are required under the 17" circular bases.
- Should the roofing manufacturer require a separation sheet between the roof and the support system, place a separation sheet or protective pad conforming to the existing roof manufacturer's system under 17" circular bases. Do not adhere to the roof system or 17" circular bases.
- Insert steel frame structures into 17" circular bases as indicated in above drawing.
- Adjust height of each support base for equal weight disbursement. Correct if necessary.
- Repeat until all support bases supplied are installed in accordance with approved shop drawings.
- Remove any unused materials and packaging from job site.

This print/image and design and detail shown hereon is the property of Advanced Support Products, Inc. This print is furnished with the understanding that it is not to be reproduced without permission, and must be returned upon demand. All rights of design and invention are reserved by Advanced Support Products.

Patents #5816554 ; #6229497; #6427965; #6448497; #6578827 © 2010